

## Mounting Instructions/Service Instructions/Spare Parts List

25 06 2001 38-069400h

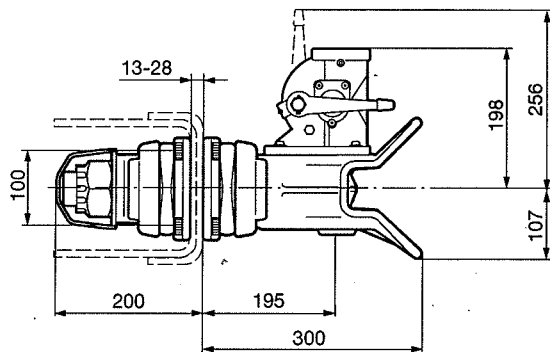

Figure 1

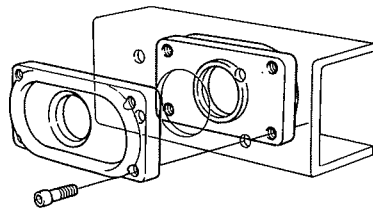

Figure 2

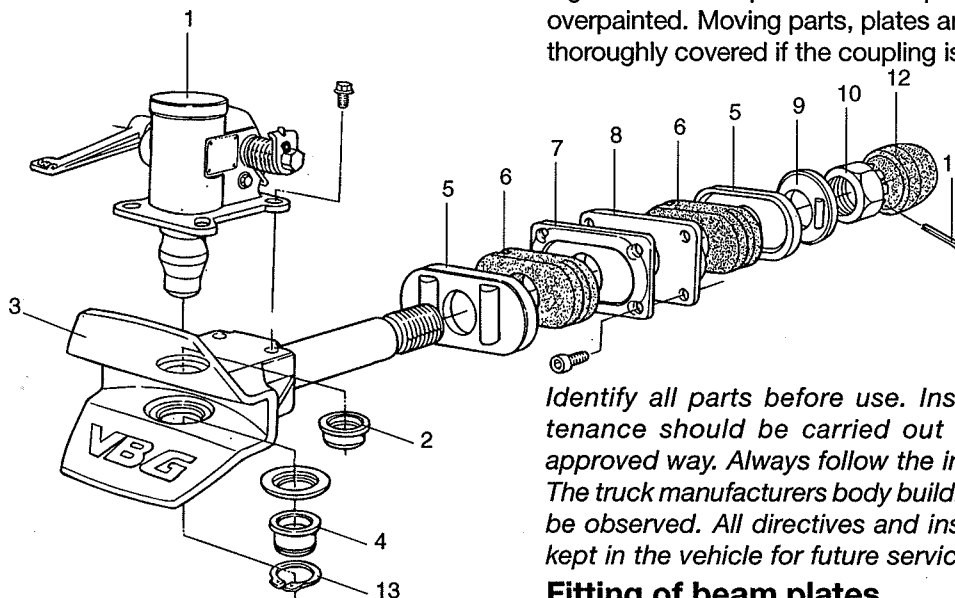

Figure 3

- |                                      |                         |
|--------------------------------------|-------------------------|
| 1 Mechanism                          | 7 Beam Plate-unthreaded |
| 2 Upper Jaw Bushing                  | 8 Beam Plate-threaded   |
| 3 Coupling Jaw with Horizontal Shaft | 9 Nut Washer            |
| 4 Lower Jaw Bushing                  | 10 Castellated Nut      |
| 5 Bearing Plate                      | 11 Split Pin            |
| 6 Rubber Block                       | 12 Nut Cover            |
|                                      | 13 Lock Washer          |

**This instruction applies also to:**

### 8500 LV or RV

-Mechanism VBG 8500 with left (LV) or right (RV) mounted handle on a coupling jaw, VBG 820.

### 8500 LK or RK

-Mechanism VBG 8500 with left (LK) or right (RK) mounted handle on a coupling jaw KRZ 500.

### General

VBG 8500 Coupling is designed for use with a  $\varnothing 50$  mm drawbar eye conforming to the ISO 1102 standard and intended for coupling a truck to a trailer with a hinged drawbar. It is not intended for dolly operation or for centre axle trailers. Installation is most safely and simply done using a VBG drawbeam. These are drilled to the ISO 3584 cat. 3 standard.

The web thickness in the middle of the drawbeam must be 13-28 mm with an inner clearance of at least 160 mm. The installation dimensions are, as shown in figure 1.

The coupling has a high-quality corrosion resistance through electrolytic pre-treatment and a top-coat with very high wear resistance. To maintain the high quality of the surface treatment, VBG recommend that no further paint is added to the coupling. If the coupling is over-painted, you run the risk of operational problems, a sticking signal/indicator pin or that important information is over-painted. Moving parts, plates and decals must all be thoroughly covered if the coupling is repainted.

*Identify all parts before use. Installation and maintenance should be carried out in the correct and approved way. Always follow the instructions.*

*The truck manufacturers body building instructions must be observed. All directives and instructions should be kept in the vehicle for future service and maintenance.*

### Fitting of beam plates

Fit the beam plates onto the drawbeam. The beam plate with threaded holes (8) should be placed inside the drawbeam. Torque up the bolts (dry) to 190 Nm (140 lbf.ft.). See figure 2.

### Fitting of coupling jaw and remaining parts

- Fit the remaining parts as shown in figure 3. Make sure that the thread of the horizontal shaft is well greased. Keep the coupling jaw horizontal whilst tightening the castellated nut by hand.

**KEEP FOR FUTURE REFERENCE**

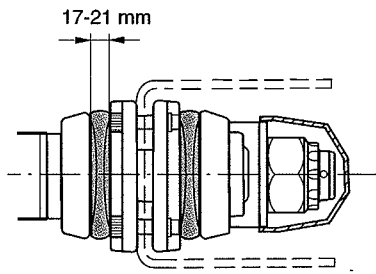

Figure 4

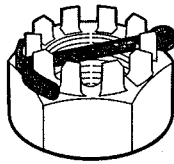

Figure 5

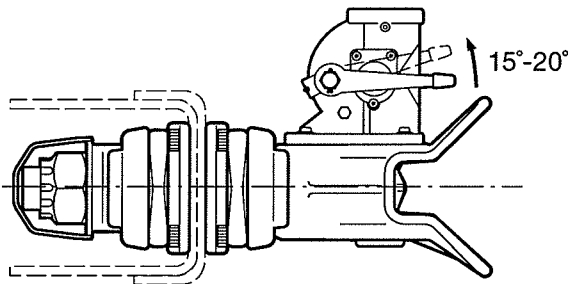
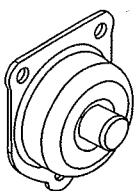
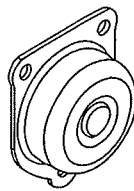

Figure 6



Non-secured/  
opened position



Secured position

Figure 7

**Make sure that that vehicle bodywork and underrun protection do not restrict the coupling articulation. When articulated vertically to 25° or rotated by 360°, 100 mm free area is required above and below the coupling.**

- To get the correct pre-loading on the rubber blocks, tighten the castellated nut until the distance between the edges of the beam plates is 17-21 mm. Use a 70 mm socket. See figure 4.
- Secure the castellated nut with a split pin 7x80. The split pin must be located totally within the gates of the nut and properly secured around it. See figure 5.
- To get the correct position of the split pin, it is sometimes necessary to add a 6 mm washer, part no.37-015700 (see spare parts list), which should then be placed under the castellated nut.
- Cover the castellated nut completely with grease and ensure that the nut cover is properly pushed onto the nut. Corrosion of the nut is thus prevented and future service made easier.

### Fitting of mechanism

- Position the mechanism onto the coupling jaw. Insert the bolts but do not tighten to full torque.
- Now check that the mechanism operates correctly and that the coupling pin in the raised position is ready for automatic coupling.
- When the mechanism is working satisfactory, tighten the bolts to a torque of 80-90 Nm (57-65 lbf. ft).
- After the installational and operational checks the mechanism should be lubricated with VBG Mechanism Oil. See figure 8.

### Checking the mechanism

- When the mechanism is in the locked position there should be play of 15°-20° at the handle before the coupling pin starts to move upwards. See figure 6.
- If there is no play or if the mechanism does not operate satisfactory, despite being properly lubricated, it should immediately be replaced.
- When the coupling pin is worn to 47.0 mm, the mechanism should be replaced. The simplest way to check the wear is to use a VBG Wear Gauge, Part No 39-004700.

Allowed vertical movement of the coupling pin in the locked position:

max	5.0 mm
Wear limit of upper jaw bushing:	max 54.0 mm
Wear limit of lower jaw bushing:	max 41.3 mm

- The mechanism is equipped with an indicator/locking device, check its function in both locked and unlocked positions. See figure 7.
- If the mechanism is equipped with a power actuator, also see separate instructions for the actuator.

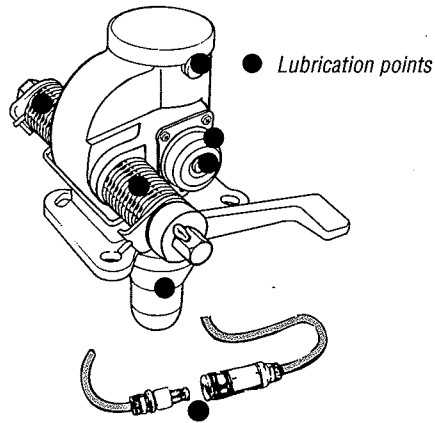

Snap-on connector for Power Actuator

Figure 8

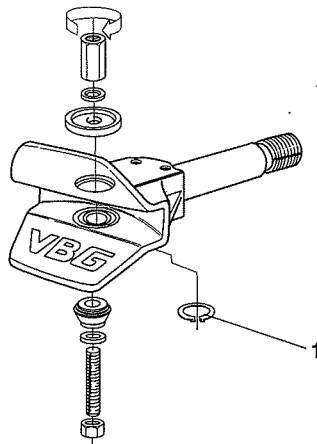

Figure 9

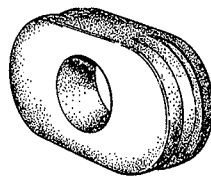

Figure 10

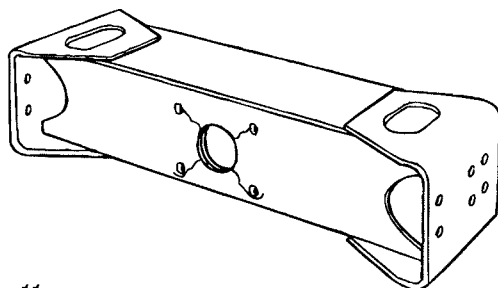

Figure 11

### Maintenance of the mechanism

- At regular intervals lubricate the mechanism with thin oil. The simplest way is to use the VBG Mechanism Oil, a specially developed oil with good cleaning and lubricating qualities. Never use grease because of its tendency to clog. For lubricating points, see figure 8.
- Maximum durability is obtained from weekly cleaning and lubricating. VBG strongly dissuade from any use of central greasing systems.
- If the coupling is equipped with a power actuator the snap-on connector should be lubricated regularly with thin oil. See figure 8.

### Renovation of the mechanism



*Never put your fingers into the coupling jaw because of the danger of them being crushed.*

- If the coupling is equipped with a power actuator, disconnect the air supply to the control box before any work is started.
- Remove the Mechanism by undo the four bolts holding the mechanism and lift it off the coupling jaw.
- When changing the Coupling Jaw Bushings, use the VBG Service Tools, Part No 39-004000. The bushings have to be pulled out upwards from the Coupling Jaw. Clean, check and lubricate the hole in the coupling jaw. Squeeze in the new bushings downwards. Remount the lock washer (1). See figure 9.
- When fitting the Mechanism, follow "Fitting of mechanism".

### Checking/Renovation of the mounting parts

- The rubber blocks are wearing parts and should be changed when they show any signs of wear, e.g. cracks, deformation, etc. If the rubber blocks are older than two years they should be automatically replaced. See figure 10.
- At regular intervals check the pre-loading on the rubber blocks. First control and inspection after 5000 km.
- Check that the bearing plates are not bent or cracked. Damaged plates should be immediately replaced.
- When the coupling is removed to change the rubber blocks, bearing plates or for any other reason, the fit of the horizontal shaft in the coupling jaw should be checked. If the horizontal shaft is loose or bent, the thread worn or the thread or coupling jaw damaged, the unit must be changed immediately.
- Also check that there are no cracks in or that there is no deformation of the drawbeam. See figure 11.

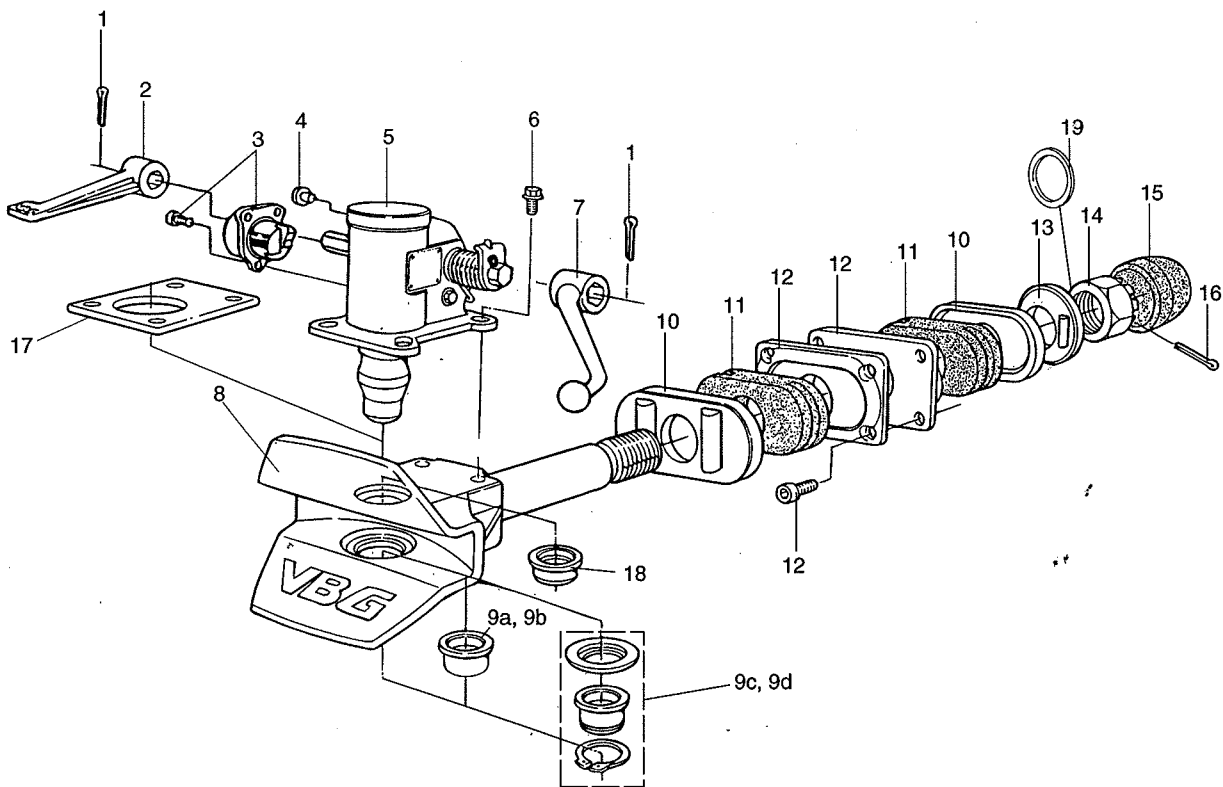

## Spare Parts List VBG 8500

Pos	Part No.	Description	Qty	Pos	Part No.	Description	Qty
1	37-014000	Split Pin	2	9b	08-008400	Lower Jaw Bushing	
2	05-079000	Handle	1			VBG 820/821, Ø38 mm	1
3	09-065900	Locking device (from 34999)	1	9c	08-016200	Lower Jaw Bushing	
	07-020500	Locking device (to 34999)	1			VBG 8500/KRZ 500, Ø40 mm	1
4	37-027700	Plastic cap 1/8" (from 34999)	1	9d	08-022700	Lower Jaw Bushing	
	37-062900	Plastic cap (to 34999)	2			VBG 8500/KRZ 500, Ø38 mm	1
5	08-021500	Mechanism VBG 8500 L *		10	05-070900	Bearing Plate	2
		with bushings	1	11	05-070800	Rubber Block	2
	08-021600	Mechanism VBG 8500 R *		12	05-075300	Beam Plates(pair) - with screws	1
		with bushings	1	13	05-076600	Washer	1
	08-021700	Mechanism VBG 8500 L *		14	36-001300	Castellated Nut	1
		with bushings VBG 820/821	1	15	05-077700	Nut Cover	1
	08-021800	Mechanism VBG 8500 R *		16	37-012100	Split Pin	1
		with bushings VBG 820/821	1	17	08-016500	Spacer Kit	1
6	07-051400	Mechanism Bolts	1	18	08-008300	Upper Jaw Bushing	
7	06-090800	Handle	1			VBG 820/821	1
8	08-016600	Coupling Jaw VBG 8500			08-008600	Upper Jaw Bushing	
		incl. pos. 6, 14-16	1			VBG 8500/KRZ500	1
9a	08-015700	Lower Jaw Bushing		19	37-015700	Washer 6 mm	1
		VBG 820/821, Ø40 mm	1				

\* "L" and "R" in the model code stands for respectively left or right handle location on VBG 820 and KRZ 500.

Note: Fitting these mechanisms on VBG 820 couplings requires an additional Spacer Kit (pos 17 Part no 08-016500).

\* If the existing mechanism is type 08-084100, 08-086000 or 08-086400 and equipped with a Power Actuator, the adapter and bracket for the Power Actuator must also be exchanged. See mounting instructions "Power Actuator RB".

VBG PRODUKTER AB reserve the right to amend or alter specifications at their discretion.



**SWEDEN:**  
**VBG PRODUKTER AB**  
 Box 1216  
 SE-462 28 VÄNERSBORG  
 Tel. +46-521- 27 77 00  
 Fax +46-521- 27 77 92  
 www.vbg.se

**NORWAY:**  
**VBG PRODUKTER A/S**  
 Postboks 94 Leirdal  
 NO-1009 OSLO  
 Tel. +47 23 14 16 60  
 Fax +47 23 14 16 61  
 www.vbg.no

**DENMARK:**  
**VBG PRODUKTER A/S**  
 Industribuen 20-22  
 DK-5592 EJBY  
 Tel. +45 64 46 19 19  
 Fax +45 64 46 10 88  
 www.vbg.dk

**GERMANY:**  
**RINGFEDER VBG GMBH**  
 Postfach 130619  
 DE-47758 KREFELD  
 Tel. +49 (0)2151-835-0  
 Fax +49 (0)2151-835-200  
 www.ringfeder.de